

SPECIFICATIONS

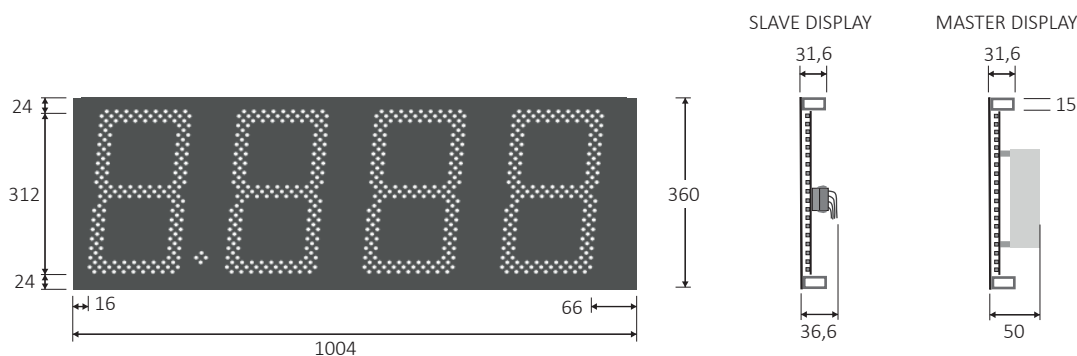

Model	Code	Details
DIS31-A-WSMD-4	D 100 001044	With Front Panel , White LED
DIS31-B-WSMD-4	D 100 001177	Without Front Panel , White LED
DIS31-A-ASMD-4	D 100 002240	With Front Panel , Amber LED
DIS31-B-ASMD-4	D 100 001179	Without Front Panel , Amber LED
DIS31-A-RSMD-4	D 100 002237	With Front Panel , Red LED
DIS31-B-RSMD-4	D 100 001178	Without Front Panel , Red LED

Description

LED display with 4 digits 312mm height. SMD LEDs suitable for continuous operation 24h / day and exposure to UV sunlight. Printed Circuit Boards coated with a special silicone resin whose formula keeps it elastic over time avoiding cracks and infiltrations of humidity, the front panel is thermo-insulated and resistant to sunlight, for LED and components protection.

Features

Operating Voltage	DC 15 V
Max Power Consumption	34 W
IP Level	SI
Operating Temperature Range	-40 °C ~ +70 °C
Storage Temperature Range	+5 °C~ +40 °C
Storage Environment Humidity	RH < 60%
Over-temperature protection	+75 °C
Viewing Angle	120°
No. LED	652
Life Time (temperature Tc = 75 °C)	100.000h (L70)
Warranty (See terms and conditions)	 3 year
Conformity	EMC Safety RoHS

LED Characteristics

Color	Luminosity
White 6500k	3200 MCD
Amber	2270 MCD
Red	1000 MCD

Models without front panel

The measurements shown on this technical specification refer to models complete with front panel, for models without front panel please contact our sales department for more details.



DEFINITION OF A LED DISPLAY SYSTEM

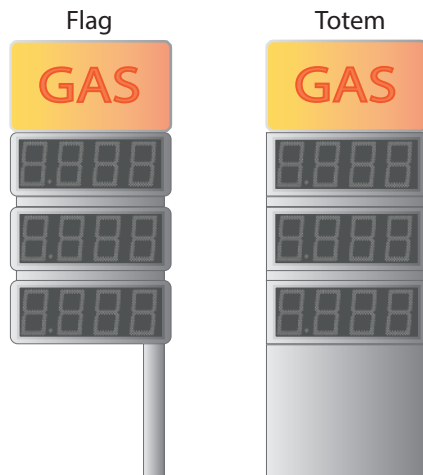

A Price System is a set of components that must be assembled and integrated into the Mini Totems, which in turn must be equipped with front windows in methacrylate or polycarbonate for the protection of the LEDs.

⚠ WARNING !! Make sure to keep a gap between the LED surface and the window glass when positioning the display. The display can be manually or automatically programmed. The Price System can be assembled as a single-sided version or a double-sided version.

How to compose a LED display system

LED DISPLAYS

Get the necessary quantity of LED displays to install on your structure.

CABLES

Select the quantity of cables required with sufficient length to connect the various LED displays to the HDP BASE controller, see on "CABLES" sheet.

HDP BASE

The standard HDP BASE controller can support up to 6 LED displays per side, for a total of 12 LED displays.

If more LED displays are needed (8 + 8 max.), it must be installed the model HDP BASE-8P, see on "ACCESSORIES" sheet.

LED DRIVER

Select the correct LED driver from the table, see on "LED DRIVER" sheet.

RDC

The 18-key remote control to program the LED displays and many other functions.

ACCESSORIES

A wide range of accessories are available and described on

LED DISPLAY

Side A

Side B

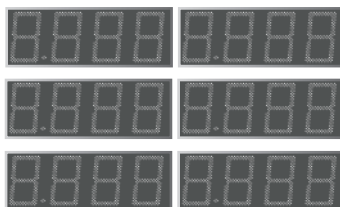

CABLE



HDP BASE



LED DRIVER



CABLES

Table of available cables to connect the various LED displays to the HDP BASE controller. The "Master display" is a display like the others, but it is considered as such because the HDP BASE controller is located behind it. All the LED displays are connected to HDP BASE, therefore the connection cable between the Master display and HDP BASE is shorter. The Master display should be installed in the lowest part of the totem.

⚠ WARNING !!

The cables must be the right length, do not let excess remain coiled up.

The cables must be fixed to structure by fastening strings, avoid leaving dangling cables because the weight would stress the connectors

Cable lenght	Code	Recommended
1800 mm	CAV 000767	Master Display
3850 mm	CAV 000768	1°,2°,3° Display
5850 mm	CAV 000769	4°,5° Display
6850 mm	CAV 000770	6°,7°,8° Display

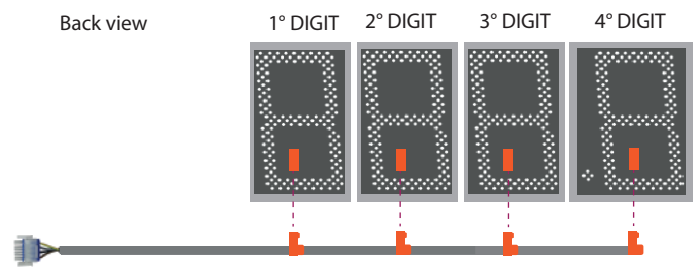

All price displays are connected to the HDP BASE which is located behind the Master display

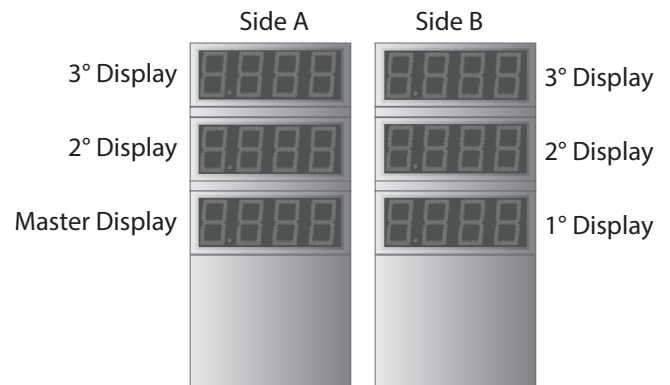
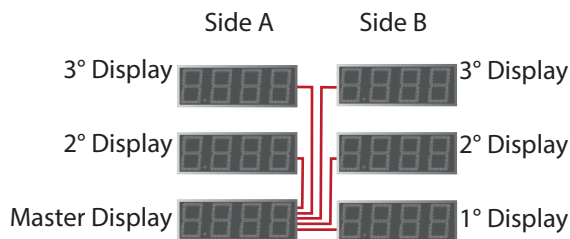

LED DRIVER

The table indicates how many and which type of LED driver are required and to which terminal blocks of the HDP BASE they must be connected. For example, a 2 + 2 system, that is 2 **HDP31** LED displays per side (double-sided), requires an **HLG-240H-15** LED driver connected to the + V1-GND terminal blocks of the HDP BASE.

Code	Model	Input	Output	Power	Overcurrent Protection	Overvoltage Protection	Overtemp. Protection	Short Circuit Protection
D 100 001240	LPF-60-15	230Vac 47 ~ 63Hz	15VDC	60W	SI	SI	SI	SI
D 100 001241	HLG-150H-15	230Vac 47 ~ 63Hz	15VDC	150W	SI	SI	SI	SI
D 100 001242	HLG-240H-15	230Vac 47 ~ 63Hz	15VDC	240W	SI	SI	SI	SI
D 100 001243	HLG-320H-15	230Vac 47 ~ 63Hz	15VDC	320W	SI	SI	SI	SI

LED driver wiring

INPUT 220 Vac - The length of 220v input cable or wires is 300 mm.

OUTPUT 15 Vdc - The length of red and black wires is 1000 mm. The wires have a ring termination and must be firmly connected to the appropriate terminal blocks on the HDP BASE.

LED display	LED Driver model	Terminal blocks on HDP BASE
1+0	LPF-60-15	+V1-GND
1+1	HLG-150H-15	+V1-GND
2+0	HLG-150H-15	+V1-GND
2+2	HLG-240H-15	+V1-GND
3+0	HLG-150H-15	+V1-GND; +V2-GND
3+3	HLG-320H-15	+V1-GND; +V2-GND
4+0	HLG-240H-15	+V1-GND; +V2-GND
4+4	HLG-240H-15	+V1-GND
	HLG-240H-15	+V2-GND
5+0	HLG-240H-15	+V1-GND; +V2-GND; +V3-GND
5+5	HLG-240H-15	+V1-GND;
	HLG-320H-15	+V2-GND; +V3-GND
6+0	HLG-320H-15	+V1-GND; +V2-GND; +V3-GND
6+6	HLG-240H-15	+V1-GND
	HLG-240H-15	+V2-GND
	HLG-240H-15	+V3-GND

WARNING !!

- The two red and black output wires 15 Vdc (1000 mm.) must not be extended.
- Connection to the line 220 VAC must be carried out by qualified personnel and must be carried out in compliance with current regulations.

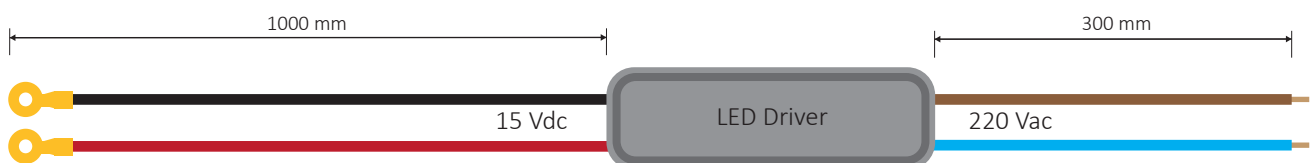

HDP BASE- CONNECTORS

The 15VDC INPUT terminal blocks named: + V1, V2, V3, V4 (positive pole) and GND (negative pole) to connect the LED drivers which are equipped with red positive and negative black wire and ring termination.

The 4-pole connectors for the LED displays are equipped with a special locking system, so you need to exert adequate pressure, making sure that it is locked correctly.

The connectors named: TWILIGHT, DISPLAY, AUX are also equipped with a special locking system as described above.

The connection to the screw terminal blocks named: ANTENNA, RS422, CURRENT LOOP must be carried out referring to the assembly instructions supplied with the product

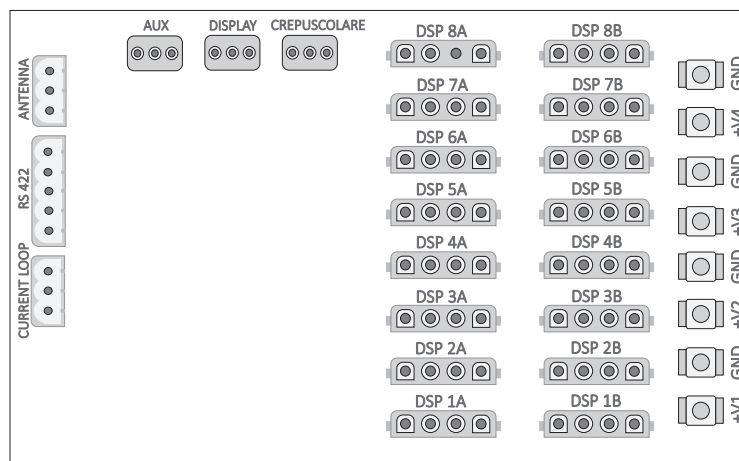

Connectors name	Function
DSP 1A.....DSP 8A	LED display connectors, only for a single side system.
DSP 1B.....DSP 8B	LED display connectors, only for the second side on a double sided system.
+V1-GND	15VDC LED driver input, to power the displays connected to DSP 1A, DSP 2A, DSP 1B, DSP 2B.
+V2-GND	15VDC LED driver input, to power the displays connected to DSP 3A, DSP 4A, DSP 3B, DSP 4B.
+V3-GND	15VDC LED driver input, to power the displays connected to DSP 5A, DSP 6A, DSP 5B, DSP 6B.
+V4-GND	15VDC LED driver input, to power the displays connected to DSP 7A, DSP 8A, DSP 7B, DSP 8B.
TWILIGHT	Optional twilight switch LS1 connection for lighting the logo, product indicators, contours, etc.
DISPLAY	Connection to graphic LCD displays for synchronized operation with price LED display.
AUX	Future use.
ANTENNA	Antenna connection for optimizing the RDC remote control signal reception.
RS 422	RS422 serial port for LAN cable connection to PC or POS with all communication protocols are available.
CURRENT LOOP	CURRENT LOOP port for connection to the POS ,this function is available only in t HDP BASE-CL or HDP BASE-8P-CL

HDP BASE- POWERING

The HDP BASE includes 4 independent banks for the LED display power (3 standard banks and the 4th bank is an optional).

On each bank there are 2 terminal blocks, positive pole and negative pole 15 VDC input, to which the eyelet terminals of the LED drivers can be screwed as well as 4 connectors (A side and B side) to which the LED displays can be plugged.

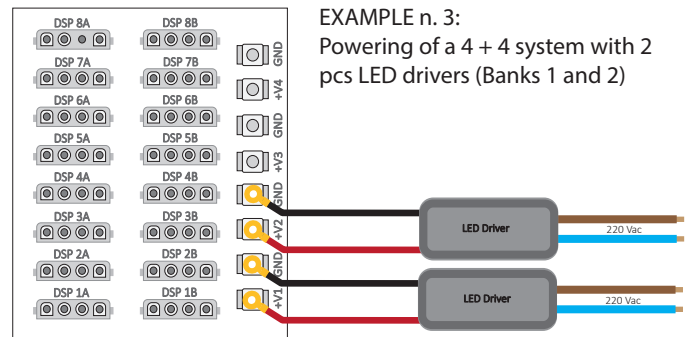
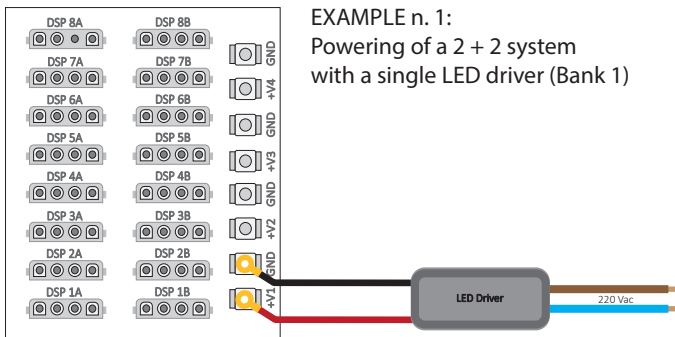
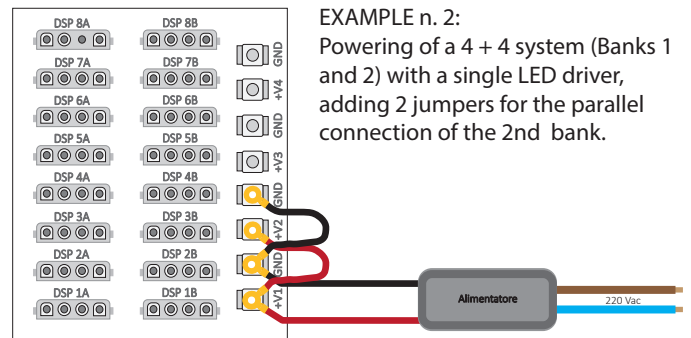
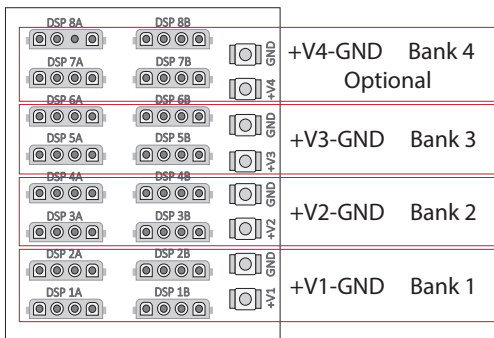

The two jumpers: positive (red wire) and negative (black wire) are used to connect 2 banks in parallel to the same LED driver.

Codice	Available jumpers
CAV 000681	Red wire jumper
CAV 000680	Black wire jumper

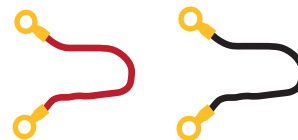

⚠ WARNING !!

- The terminal block screws must be tightly screwed to avoid overheating due to high current (A)

PROGRAMMING



Remote radio control RDC

Remote radio control for manual programming: entering prices on the numeric displays, selecting of graphic programs on the panel (if present) and many other setting functions.

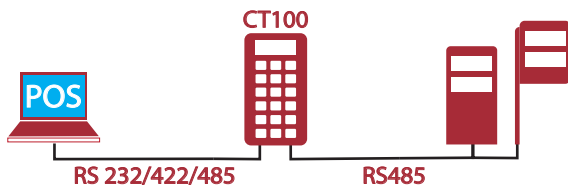

Keyboard CT100

The CT100 keyboard for manual programming: entering prices on the numeric displays, selecting of graphic programs on the panel (if present) and many other setting functions. or it can become transparent allowing programming directly from the POS via communication protocols, or both modes at the same time, using a category 5 LAN cable for data connection (maximum cable length: 1000 m).

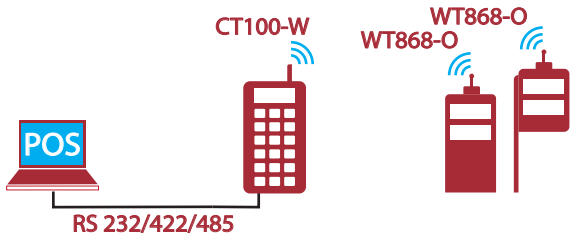

Wireless Keyboards CT100-W

The CT100W keyboard for manual programming: entering prices on the numeric displays, selecting of graphic programs on the panel (if present) and many other setting functions. or it can become transparent allowing programming directly from the POS via communication protocols, or both modes at the same time. Wireless connection data. The range is approximately 100 linear meters in open field (one WT 868-O receiver must be used for each display system).



Directly connection to POS (Wired)

Programming one or more LED display systems via POS by connecting a category 5 LAN cable (maximum cable length: 1000m). In case of POS all communication protocols listed on the next page are available, it is possible to use the remote control at the same time. If necessary add a interface CONV-SU01, RS422 serial converter (optional).

AVAILABLE COMMUNICATION PROTOCOLS



- PC LEDPRO
- HITECH 1200Hz
- OMV



- TOKHEIM KA (KOPPENS AUTOMATIC) ver. 4.2
- TOKHEIM JUPITER ST 39



- PROEDA V21-02-01/CK



- LOGITRON GILBARCO 70RPLSUPSIT.E04 (PASSPORT EUROPE)
- ENI
- GILBARCO EXTENDED



- SCHEIDT & BACHMANN V11



- SCHENK 68000/68020 ver.2.02 2400 BAUD RATE
- SCHENK 68000/68020 ver.2.02 4800 BAUD RATE



- WAYNE DRESSER SYSTEM MARKETER PIGNONE SM2000/3000
- WAYNE DRESSER NUCLEUS 8 (1200 BAUD RATE ONE-WAY)
- WAYNE DRESSER NUCLEUS 9 (9600 BAUD RATE BIDIRECTIONAL)
- HITECH_PIGNONE-TON1070S
- ENI
- WAYNE DRESSER EXTENDED BIDIRECTIONAL



- IFSF LON WORK (An additional interface is needed)



- MASER AUTOMATION



- LAFON - MAGIC 2000



- FORTECH



- ALVIC

ACCESSORIES



Code	Model	Description
D 100 001032	RDC	Remote radio Control
D 100 002322	CT100	Wired Keyboard
D 100 002582	CT100-W	Wireless Keyboard
D 100 002583	WT868-O	Wireless Receiver
D 100 002200	CONV_SU01	USB - RS422 Converter
O 091 000405	ANT433-4	External Antenna for RDC

Code	Model	Description
D 100 002285	YAGI868	Yagi Antenna
D 100 001992	LS2-HDP	Twilight
D 100 002336	SP HDP BASE	Protection for HDP BASE
D 100 001255	HDP BASE-8P	Version up to 8+8 lines price
D 100 001257	HDP BASE-CL	Version with current loop
D 100 001258	HDP BASE-8P-CL	Vers. 8+8 lines p. and current loop

** Please request these variables when ordering, this option cannot be added later.

QUALITA'

Protective coating

The considerable thermal excursion and the high moisture to which the LED displays are subjected, driven Hitechled design department to prefer a protection of the electronic boards made of pure silicone. This material, unlike common protective resins, has the advantage of always remaining elastic and unaltered over time, avoiding cracks and related moisture infiltrations.

The dosage of this precious material is performed by automatic machines, avoiding to deposit sediments on the surface of the LEDs.

Sealed connectors

The rugged connectors designed for the industrial sector are equipped with protective silicone seals into the gap between the male and female socket and in the collars around the wires. The safety lock ensures a stable connection, thus avoiding malfunctions due to hasty wiring. The contacts coated with anti-oxidation metal are suitable for use in humid environments and guarantee a considerable duration over time.

LEDs controlled by constant current drivers

LED displays are equipped with constant current drivers, furthermore the LEDs are divided into many branches and connected together in series of only 4 units, this serves to minimize the problem of illegibility in the event that a spoiled.

The brightness of the LEDs is automatically adjusted by the microprocessor integrated in each single digit with PWM (Pulse With Modulation) procedure.

Overheating protection for LEDs

An integrated temperature micro-sensor reduces the current in the LEDs in case of ambient overtemperature, then bringing it back to the normal level with the restoration of the temperature values below the limit, this automatic system serves to avoid premature aging of the LEDs, allowing them to age in accordance with the manufacturer's expected derating curve in the 100,000 hours of operating life of the LEDs.

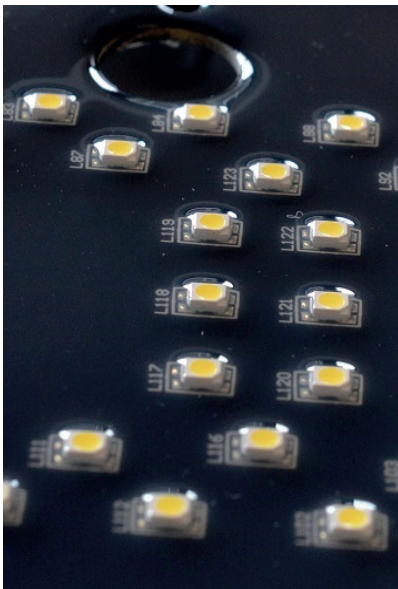

QUALITA'

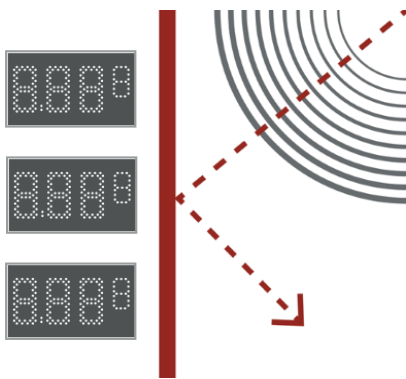

Sturdy wiring and high immunity to interference

The connection between the HDP BASE and the LED displays consists of a single cable with 4 wires (double insulation) and therefore mechanically robust, so the cables can be fixed to the structure by fastening strings.

The HDP BASE is equipped with 16 independent RS485 serial communication channels, one for each single LED display which are each equipped with a microprocessor that decrypts and correctly displays the prices arriving from the HDP BASE. The hardware thus designed in addition to the software filters of the main microprocessor makes communication extremely safe and immune to electromagnetic disturbances, avoiding to display of wrong or deformed characters.

Opto Isolated communication serial port

The optical device for the galvanic separation of the RS422 / 485 communication serial port included on the HDP BASE, establishes a very high level of immunity to electrical discharges induced in the cable towards the POS.

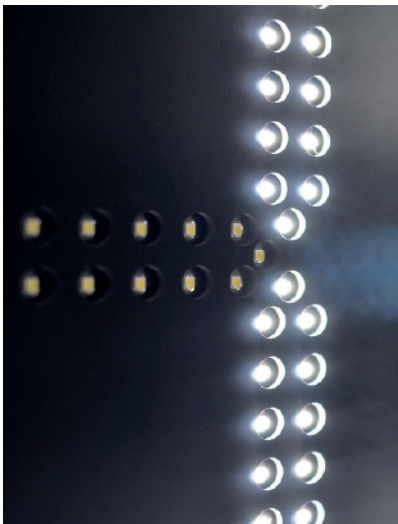

Resistance to solar radiation and temperature

All the LED displays are equipped with a sunshade front in non-deformable in fiber-glass which being a poor conductor of heat, plays a role of heat shield and protection from the effects of solar radiation as well as finishing the display.

Brightness sensor on each LED display

Each individual LED display is equipped with a brightness sensor, all the displays connected to the DSP 1A ... DSP 8A connectors measure continuously the amount of ambient light and send this value to the HDP BASE board, consequently the brightness of the all LED display connected to HDP BASE (A side and B side) is automatically adjusted, optimizing consumption and making the reading of the displays more comfortable.